



## Inline filter with filter element according to DIN 24550

Type 350LEN0040 to 1000; 350LE0130, 0150

**RE 51422**  
 Edition: 2021-04  
 Replaces: -



350LEN\_d

- ▶ Size as per **DIN 24550**: 0040 to 1000
- ▶ Other sizes: 0130, 0150
- ▶ Nominal pressure: 350 bar [5,079 psi]
- ▶ Connection sizes up to G2; SAE 2"; SAE 24
- ▶ Operating temperature: -10 °C to 100 °C [14 °F to 212 °F]

### Features

Inline filters are used in hydraulic systems for separating solid materials from fluids and lubricating oils.

- They come with the following features:
- ▶ Filter for inline installation
  - ▶ Special, highly efficient filter materials
  - ▶ Filtration of very fine particles and high dirt holding capacity across a broad pressure differential range
  - ▶ High collapse rating of the filter elements
  - ▶ Equipped standard with mechanical optical maintenance indicator with memory function
  - ▶ Various, optional electronic switching elements, modular design
  - ▶ Optional bypass valve integrated in the filter housing
  - ▶ High filtration performance due to tangential, cyclonic flow path
  - ▶ Additional configurations available for special fluids

### Contents

Features	1
Filter ordering code	2, 3
Preferred types	4
Accessories ordering code	5
Filter design	6
Symbols	7
Function, cross-section	8
Technical data	9, 10
Compatibility with permitted hydraulic fluids	11
Dimensions	12
Maintenance indicator	13
Spare parts ordering codes	14 ... 16
Assembly, commissioning, maintenance	17
Tightening torques	18
Directives and standardization	18, 19

RE 51422, edition: 2021-04, Hengst Filtration GmbH

2/20 **350LEN0040 to 1000; 350LE0130, 0150** | Inline filter

## Filter ordering code

01	02	03	04	05	06	07	08	09	10
350LE			-			-	-	-	-

### Series

01	Inline filter, 350 bar [5,079 psi]	350LE
----	------------------------------------	-------

### Filter element

02	With filter element as per <b>DIN 24550</b>	N
----	---	---

### Size

03	LEN... (Filter element as per <b>DIN 24550</b> )	0040 0063 0100 0160 0250 0400 0630 1000
	LE... (Filter element as per <b>Hengst standard</b> )	0130 0150

### Filter rating in µm

04	<b>Absolute</b> (ISO 16889; $\beta_{x(c)} \geq 200$ )	Glass fiber material, not cleanable	PWR3 PWR6 PWR10 PWR20
	<b>Nominal</b>	Stainless steel wire mesh, cleanable	G10 G25 G40 G60 G100

### Pressure differential

05	Max. admissible filter element pressure differential: 30 bar [435 psi], filter <b>with</b> bypass valve	A
	Max. admissible filter element pressure differential: 330 bar [4,786 psi], filter has <b>no</b> bypass valve	B

### Element design

06	Standard adhesive with galvanized steel	00
	Special adhesive with stainless steel	HV <sup>1)</sup>

### Maintenance indicator

07	Maintenance indicator, mech. visual, switching pressure: 2.2 bar [32 psi] – bypass cracking pressure: 3.5 bar [51 psi]	V2.2
	Maintenance indicator, mech. visual, switching pressure: 5.0 bar [72.5 psi] – bypass cracking pressure: 7 bar [102 psi]	V5.0
	Maintenance indicator, mech. visual, switching pressure 8.0 bar [116 psi] – <b>no</b> bypass valve	V8.0

### Seal

08	NBR seal	M
	FKM seal	V
	EPDM seal	E <sup>2)</sup>

## Filter ordering code

01	02	03	04	05	06	07	08	09	10
350LE			-			-	-	-	

### Connection

09	Installation size		0040	0063-0100	0130-0150	0160-0400	0630-1000	
	<b>Connection</b>							
	G1/2	Pipe thread as per ISO 228	●	X				R2
	G3/4		X	X				R3
	G1		X	●	X			R4
	G1 1/4				●	X		R5
	G1 1/2				X	●		R6
	G2						●	R8
	SAE 1 1/2"	SAE flange 6,000 psi				X		S6
	SAE 2"						X	S8
	SAE 10"	Pipe thread as per SAE J1926	X					U3
	SAE 12"			X				U4
	SAE 20"				X			U5
	SAE 24"					X		U6
			●	Standard connection				
			X	Alternative connection option				

### Supplementary information

10	Manufacturer's inspection certificate M as per DIN 55350 T18	Z1
----	--	----

- 1) Only with FKM or EPDM seal
- 2) Only with maintenance indicator V5.0

### Order example:

**350LEN0100-PWR10A00-V5.0-M-R4**

Other versions are available on request.

4/20 **350LEN0040 to 1000; 350LE0130, 0150** | Inline filter

## Preferred types

**350LE(N), flow specifications for 30 mm<sup>2</sup>/s [143 SUS]**

### Inline filter, 3 µm filter rating

Type	Flow in l/min [US gpm] whereas Δp = 1.5 bar [21.76 psi] <sup>1)</sup>	Material no. Filter				Replacement element material no.
		...R2	R928033024	...U3	R928033216	
350LEN0040-PWR3A00-V5.0-M-...	32 [8.5]	...R2	R928033024	...U3	R928033216	R928006645
350LEN0063-PWR3A00-V5.0-M-...	48 [12.7]	...R4	R928033025	...U4	R928033217	R928006699
350LEN0100-PWR3A00-V5.0-M-...	64 [16.9]	...R4	R928033026	...U4	R928033218	R928006753
350LE0130-PWR3A00-V5.0-M-...	103 [27.2]	...R5	R928033027	...U5	R928033219	R928022274
350LE0150-PWR3A00-V5.0-M-...	127 [33.6]	...R5	R928033028	...U5	R928033220	R928022283
350LEN0160-PWR3A00-V5.0-M-...	160 [42.3]	...R6	R928033029	...U6	R928033221	R928006807
350LEN0250-PWR3A00-V5.0-M-...	267 [70.5]	...R6	R928033030	...U6	R928033222	R928006861
350LEN0400-PWR3A00-V5.0-M-...	335 [88.5]	...R6	R928033031	...U6	R928033223	R928006915
350LEN0630-PWR3A00-V5.0-M-...	449 [118.6]	...R8	R928034432	...S8	R928034448	R928006969
350LEN1000-PWR3A00-V5.0-M-...	597 [157.7]	...R8	R928034433	...S8	R928034449	R928007023

### Inline filter, 6 µm filter rating

Type	Flow in l/min [US gpm] whereas Δp = 1.5 bar [21.76 psi] <sup>1)</sup>	Material no. Filter				Replacement element material no.
		...R2	R928033280	...U3	R928033472	
350LEN0040-PWR6A00-V5.0-M-...	41 [10.8]	...R2	R928033280	...U3	R928033472	R928006646
350LEN0063-PWR6A00-V5.0-M-...	69 [18.2]	...R4	R928033281	...U4	R928033473	R928006700
350LEN0100-PWR6A00-V5.0-M-...	104 [27.5]	...R4	R928033282	...U4	R928033474	R928006754
350LE0130-PWR6A00-V5.0-M-...	125 [33]	...R5	R928033283	...U5	R928033475	R928022275
350LE0150-PWR6A00-V5.0-M-...	135 [35.7]	...R5	R928033284	...U5	R928033476	R928022284
350LEN0160-PWR6A00-V5.0-M-...	265 [70]	...R6	R928033285	...U6	R928033477	R928006808
350LEN0250-PWR6A00-V5.0-M-...	320 [84.5]	...R6	R928033286	...U6	R928033478	R928006862
350LEN0400-PWR6A00-V5.0-M-...	400 [105.7]	...R6	R928025783	...U6	R928033479	R928006916
350LEN0630-PWR6A00-V5.0-M-...	520 [137.4]	...R8	R928034464	...S8	R928034480	R928006970
350LEN1000-PWR6A00-V5.0-M-...	635 [167.8]	...R8	R928034465	...S8	R928034481	R928007024

### Inline filter, 10 µm filter rating

Type	Flow in l/min [US gpm] whereas Δp = 1.5 bar [21.76 psi] <sup>1)</sup>	Material no. Filter				Replacement element material no.
		...R2	R928033536	...U3	R928033728	
350LEN0040-PWR10A00-V5.0-M-...	51 [13.5]	...R2	R928033536	...U3	R928033728	R928006647
350LEN0063-PWR10A00-V5.0-M-...	76 [20.1]	...R4	R928033537	...U4	R928033729	R928006701
350LEN0100-PWR10A00-V5.0-M-...	100 [26.4]	...R4	R928033538	...U4	R928033730	R928006755
350LE0130-PWR10A00-V5.0-M-...	191 [50.5]	...R5	R928025653	...U5	R928033731	R928022276
350LE0150-PWR10A00-V5.0-M-...	202 [53.4]	...R5	R928028868	...U5	R928033732	R928022285
350LEN0160-PWR10A00-V5.0-M-...	261 [69]	...R6	R928033541	...U6	R928033733	R928006809
350LEN0250-PWR10A00-V5.0-M-...	330 [87.2]	...R6	R928033542	...U6	R928033734	R928006863
350LEN0400-PWR10A00-V5.0-M-...	409 [108.1]	...R6	R928033543	...U6	R928033735	R928006917
350LEN0630-PWR10A00-V5.0-M-...	590 [155.9]	...R8	R928034496	...S8	R928034512	R928006971
350LEN1000-PWR10A00-V5.0-M-...	650 [171.7]	...R8	R928034497	...S8	R928034513	R928007025

<sup>1)</sup> Measured pressure differential across filter and measuring equipment in accordance with ISO 3968. The measured pressure differential at the maintenance indicator is lower.

**Accessories ordering code**  
 (dimensions in mm [inch])

**Electronic switching element for maintenance indicators**

01	02	03
WE	-	-

**Maintenance indicator**

01	Electronic switching element	WE
----	------------------------------	----

**Type of signal**

02	1 switching point	1SP
	2 switching points, 3 LEDs	2SP
	2 switching points, 3 LEDs and signal suppression up to 30 °C [86 °F]	2SPSU

**Plug**

03	M12x1, 4-pole round plug-in connection	M12x1
	2-pole rectangular plug-in connection, design A as per EN 175301-803	EN 175301-803

**Material numbers for electronic switching elements**

Material no.	Type	Signal	Switching points	Plug	LEDs
R928028409	WE-1SP-M12x1	Changeover	1	M12x1	0
R928028410	WE-2SP-M12x1	Normally open (at 75%)/ normally closed contact (at 100%)	2		3
R928028411	WE-2SPSU-M12x1				
R928036318	WE-1SP-EN175301-803	Normally closed contact	1	EN 175301-803	0

**Mating connectors** (max. admissible voltage: 50 V)

For electronic switching element with M12x1 round plug-in connection

Mating connector fitting M12x1,  
 4-pole K24 with screw connection, Pg9 cable gland.

**Material no. R900031155**

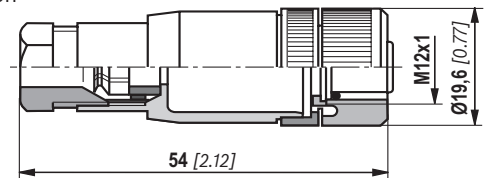

Mating connector fitting M12x1,  
 4-pole K24-3m with potted-in PVC cable, 3 m long.  
 Line cross-section: 4 x 0.34 mm<sup>2</sup>

Core marking:     **1** brown           **2** white  
                       **3** blue             **4** black

**Material no. R900064381**

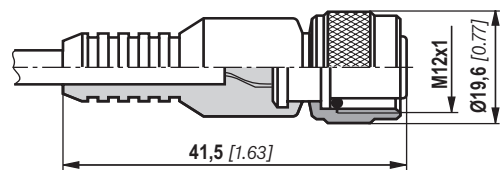

For more round plug-in connections, see data sheet 08006.

**Order example:**

Inline filter with mechanical visual maintenance indicator for  $p_{nom} = 350 \text{ bar}$  [5,079 psi] with bypass valve, size 0100, with 10 µm filter element and M12x1 electronic switching element with 1 switching point for HLP mineral oil hydraulic fluid as per DIN 51524.

**Filter with mech. visual maintenance indicator:** 350LEN0100-PWR10A00-V5.0-M-R4     **Material no. R928033538**

**Electronic switching element:** WE-1SP-M12x1     **Material no. R928028409**

**Mating connector:** Mating connector fitting M12x1, 4-pole K24     **Material no. R900031155**

6/20 **350LEN0040 to 1000; 350LE0130, 0150** | Inline filter

## Filter design

Easy selection of the filter size is made possible by the FilterSelect online tool. The filter can be designed using the operating pressure, flow and fluid system parameters. The required filter rating is based on the application, the sensitivity to contamination of the components and the environmental conditions.

The program leads you through the menu on a step-by-step basis.

A documentation of the filter selection can finally be created in the form of a PDF file. This file contains the entered parameters, the designed filter with material number including spare parts, and the pressure loss curves.

Link FilterSelect:  
<http://www.filterselect.de>

Other languages can be selected using the page navigation.

### standard search

application:	<input type="text" value="hydraulics for industrial use and applications with lubricating oil"/>
Product category:	<input type="text" value="please select"/>
type:	<input type="text" value="please select"/>
pressure range:	<input type="text" value="please select"/>
filter material:	<input type="text" value="please select"/>
fineness:	<input type="text" value="please select"/>
volume flow rate:	<input type="text" value=""/> <input type="text" value="l/min"/>
viscosity: * = working point	<input checked="" type="radio"/> kin viscosity 1: <input type="text" value="32"/> <input type="text" value="mm²/s"/>
	<input type="radio"/> search via type of medium <input type="text" value="please select"/> full-text search medium <input type="text" value=""/>
	<input type="radio"/> dyn. Viscosity 1: <input type="text" value=""/> [cP] density 1: <input type="text" value=""/> [kg/dm³] kin viscosity 1: <input type="text" value=""/> [mm²/s]
collapse pressure resistance according to ISO 2941:	<input type="text" value="30 bar"/>
	<input type="button" value="Start search"/>

## Symbols

**Inline filter**  
with bypass  
and mechanical indicator

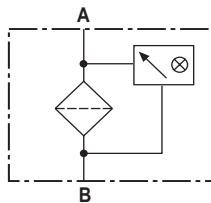
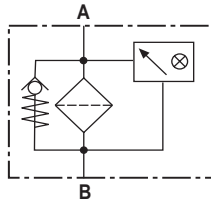

**Inline filter,**  
no bypass,  
with mechanical indicator

**Electronic switching element  
for maintenance indicator**

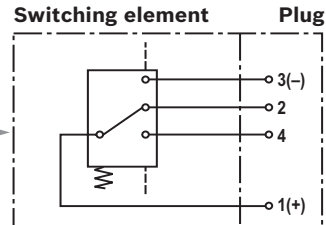

**WE-1SP-M12x1**

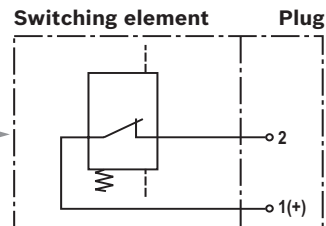

**WE-1SP-EN175301-803**

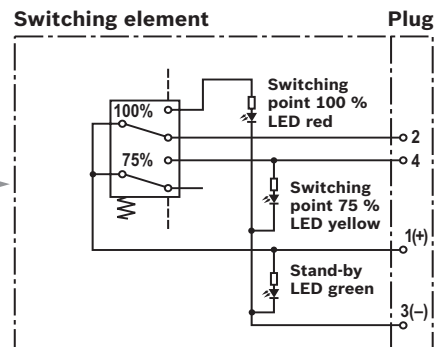

**WE-2SP-M12x1**

Circuit diagram drawn in plugged condition (operating state)

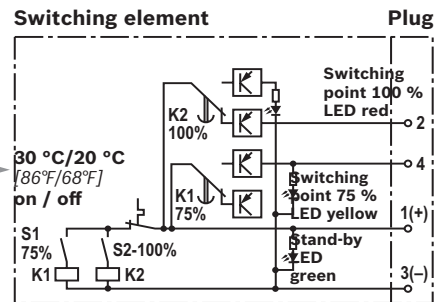

**WE-2SPSU-M12x1**

Circuit diagram drawn in plugged condition at temperature > 30 °C [86 °F] (operating state)

8/20 **350LEN0040 to 1000; 350LE0130, 0150** | Inline filter

## Function, cross-section

The 350LE(N) inline filter is designed for direct installation into pressure lines.

It consists primarily of a filter head (1), a threaded filter bowl (2), a filter element (3) and a mechanical optical maintenance indicator (4). For filters with low collapse filter elements (= pressure differential code letter A), a bypass valve (5) comes standard.

The fluid passes through the inlet to the filter element, where it is cleaned. Any dirt particles filtered out collect in the filter element. The filtered fluid then enters the hydraulic circuit through the outlet.

The filter housing and all connection elements are designed so that pressure spikes – as they may occur, e.g., due to an accelerated fluid quantity from large control valves opening abruptly – can be safely absorbed. Sizes 0160 and larger come with a drain screw (6) standard. Size 1000 comes with a two-part filter bowl, with the filter bowl fixed to prevent the bowl from spinning in the filter head.

An electronic switching element (7) can be added to the mechanical optical maintenance indicator in order to integrate it into an electric circuit. The electronic switching element must be attached to the mechanical visual maintenance indicator and held with the locking ring supplied. The electronic switching elements are connected with a mating connector or cable connection. The electronic switching element must be ordered separately.

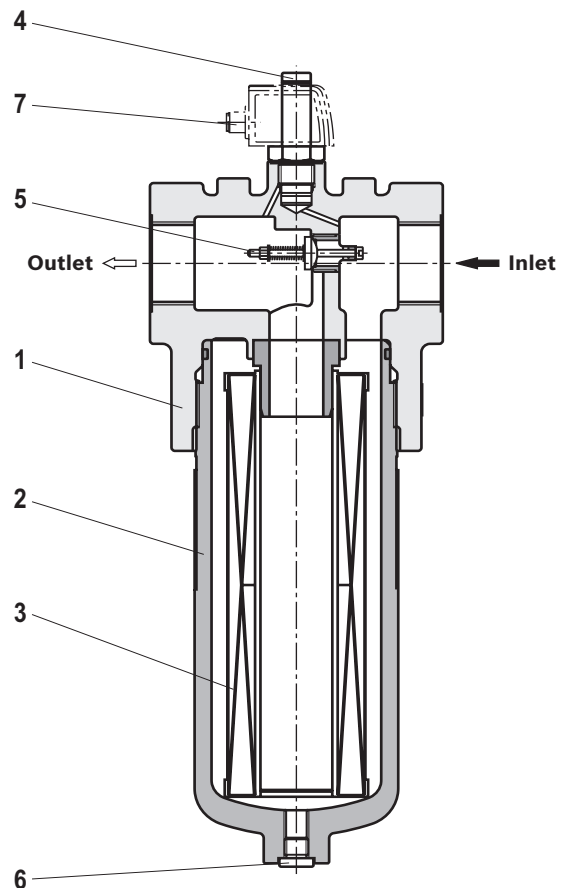

### WARNING

- If the maintenance indicator is ignored when an element change is required, there is the possibility the filter will go into bypass and contaminated oil will pass to the clean side of the filter outlet. Therefore the filtration effectiveness is no longer guaranteed.

Hengst Filtration GmbH, RE 51422, edition: 2021-04

Knowledge is POWER – Motion Force Control is our Business

HYQUIP Limited New Brunswick Street Horwich Bolton Lancashire BL6 7JB UK

## Technical data

(Please consult us for applications outside these parameters)

General							
Installation position		Vertical					
Ambient temperature range	°C [°F]	-10 to +65 [14 to 149] (down to -30 [-22] for brief periods)					
Storage conditions	▶ NBR/EPDM seal	°C [°F] -40 to 65 [-40 to 149]; max. relative air humidity: 65%					
	▶ FKM seal	°C [°F] -20 to 65 [-4 to 149]; max. relative air humidity: 65%					
Weight	▶ Filter	Size	<b>0040</b>	<b>0063</b>	<b>0100</b>	<b>0130</b>	<b>0150</b>
		kg [lbs]	4.4 [9.7]	5.0 [11.1]	5.9 [13.0]	10.5 [23.2]	11.2 [24.8]
	▶ Filter bowl	Size	<b>0160</b>	<b>0250</b>	<b>0400</b>	<b>0630</b>	<b>1000</b>
		kg [lbs]	17.2 [30.0]	19.5 [43.1]	23.0 [50.8]	45.0 [99.5]	93.0 [205.6]
		Size	<b>0040</b>	<b>0063</b>	<b>0100</b>	<b>0160</b>	
		kg [lbs]	1.3 [2.9]	1.3 [2.9]	2.1 [4.6]	5.5 [12.1]	
Flow	▶ Filter bowl	Size	<b>0250</b>	<b>0400</b>	<b>0630</b>	<b>1000</b>	
		kg [lbs]	8.0 [17.6]	12.2 [26.9]	21.4 [47.2]	Filter pipe <sup>1)</sup> 45.3 [99.8] End cap 2.0 [4.4]	
	▶ Filter head	Size	<b>0040</b>	<b>0063</b>	<b>0100</b>	<b>0130</b>	<b>0150</b>
		l [US gal]	0.3 [0.1]	0.4 [0.1]	0.5 [0.1]	0.9 [0.2]	1.1 [0.3]
Material	▶ Filter head	Size	<b>0160</b>	<b>0250</b>	<b>0400</b>	<b>0630</b>	<b>1000</b>
		l [US gal]	1.3 [0.3]	1.9 [0.5]	3.0 [0.8]	4.5 [1.2]	6.5 [1.7]
Material	▶ Filter head	Ductile iron					
	▶ Filter bowl	Steel					
	▶ Bypass valve	PA6 / steel / POM					
	▶ Seals	NBR or FKM					
	▶ Visual maintenance indicator	Brass					
	▶ Electronic switching element	Nylon 6 plastic					

Hydraulics			
Max. operating pressure	bar [psi]	350 [5,079]	
Hydraulic fluid temperature range	°C [°F]	-10 to 100 [14 to 212] (down to -30 [-22] for brief periods)	
Min. medium conductivity	pS/m	300	
Fatigue strength as per ISO 10771	load cycles	> 10 <sup>6</sup> at max. operating pressure	
Maintenance indicator pressure measurement type	Pressure differential		
Assignment: Maintenance indicator response pressure/ bypass valve cracking pressure		Maintenance indicator response pressure	Bypass valve cracking pressure
	bar [psi]	2.2 ± 0.3 [31.9 ± 4.4]	3.5 ± 0.35 [50.8 ± 5.1]
	bar [psi]	5.0 ± 0.5 [72.5 ± 7.3]	7.0 ± 0.5 [101.5 ± 7.3]
	bar [psi]	8.0 ± 0.8 [116 ± 11.6]	No bypass valve
Direction of filtration	From the outside to the inside		

<sup>1)</sup> This weight is not relevant to changing the filter element, since only the cap has to be unscrewed.

10/20 **350LEN0040 to 1000; 350LE0130, 0150** | Inline filter

## Technical data

(Please consult us for applications outside these parameters)

Electrical (electronic switching element)				
Electrical connection	M12x1, 4-pole round plug-in connection			EN 175301-803 standard connection
Version	WE-1SP-M12x1	WE-2SP-M12x1	WE-2SPSU-M12x1	WE-1SP-EN175301-803
Contact load, DC voltage	$A_{max.}$	1		
Voltage range	$V_{max.}$	150 (AC/DC)	10 – 30 (DC)	250 (AC) / 200 (DC)
Max. switching power with resistive load	W	20		70
Switching type	▶ 75% signal	–	Normally open contact	–
	▶ 100% signal	Changeover	Normally closed contact	Normally closed contact
	▶ 2SPSU		Signal inter-connection at 30 °C [86 °F], return switching at 20 °C [68 °F]	
LED indicators in 2SP electronic switching elements		Stand-by (LED green) 75% switching point (LED yellow) 100% switching point (LED red)		
IP rating as per EN 60529	IP	67		65
Ambient temperature range	°C [°F]	-25 to 85 [-13 to 185]		
Include spark extinguishing for DC voltage above 24 V to protect the switching contacts.				
Weight Electronic switching element	kg [lbs]	0.1 [0.22]		

Filter element			
Glass fiber material PWR..		Inorganic fiber-based single-use element	
		Filtration ratio as per ISO 16889 up to $\Delta p = 5$ bar [72.5 psi]	Best oil cleanliness as per ISO 4406 [SAE-AS 4059]
	PWR20	$\beta_{20}(c) \geq 200$	19/16/12 – 22/17/14
	PWR10	$\beta_{10}(c) \geq 200$	17/14/10 – 21/16/13
	PWR6	$\beta_6(c) \geq 200$	15/12/10 – 19/14/11
	PWR3	$\beta_5(c) \geq 200$	13/10/8 – 17/13/10
Admissible pressure differential	▶ A	bar [psi]	30 [435]
	▶ B	bar [psi]	330 [4,785]

For detailed information on Hengst filter elements, see data sheet 51420.

## Compatibility with permitted hydraulic fluids

Hydraulic fluid	Classification	Suitable sealing materials	Suitable adhesive	Standards	
Mineral oil	HLP	NBR	Standard	DIN 51524	
Biodegradable	▶ Water insoluble	HETG		NBR	VDMA 24568
		HEES		FKM	VDMA 24568
	▶ Water soluble	HEPG		FKM	VDMA 24317
Flame-resistant	▶ Waterless	HFDU, HFDR		FKM	DIN 24320
		HFAS		NBR	VDMA 24317
	▶ Aqueous	HFAE		NBR	
		HFC		NBR	
	▶ Skydrol	–	EPDM	Special "H"	



### Important information on hydraulic fluids:

- ▶ For more information and data on the use of other hydraulic fluids, see data sheet 90220 or contact us.
- ▶ **Flame-resistant, aqueous:** Due to possible chemical reactions with materials or machine and system component surface coating, the service life with these hydraulic fluids may be less than expected.

- Do not use filter materials made of filter paper P, use filter elements with glass fiber filter material instead.
- ▶ **Biodegradable:** If filter materials made of filter paper are used, the filter life may be shorter than expected due to material incompatibility and swelling.

12/20 350LEN0040 to 1000; 350LE0130, 0150 | Inline filter

## Dimensions: 350LE(N) sizes 0040 to 1000 (Dimensions in mm [inch])

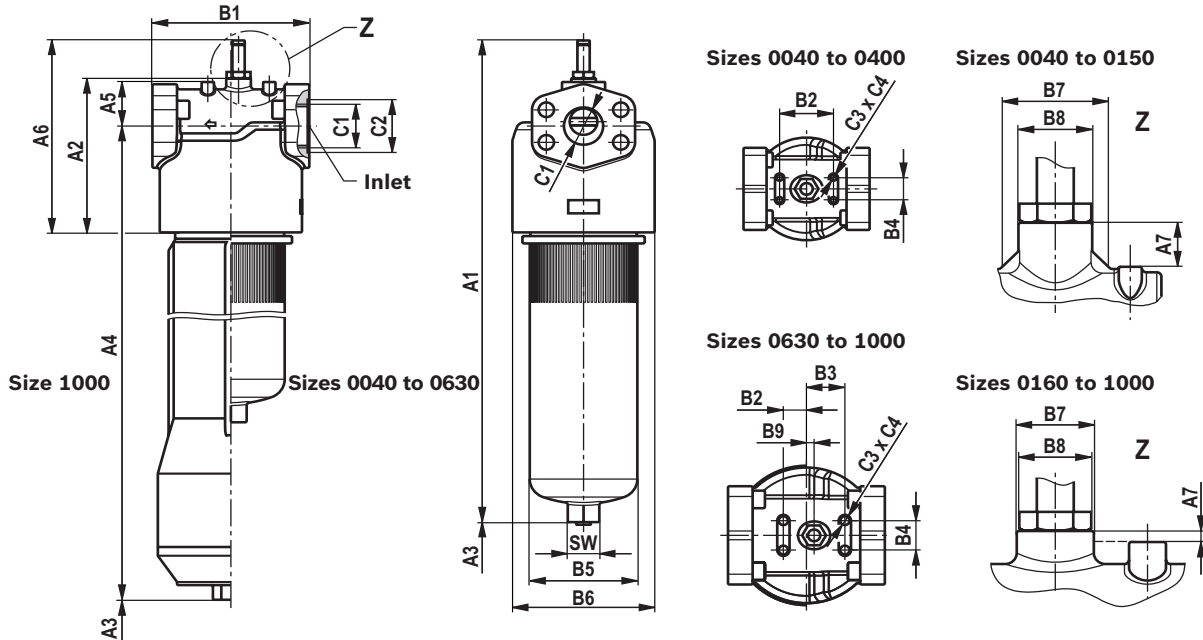

Type 350...	A1	A2	A3 <sup>1)</sup>	A4	A5	A6	A7	B1 <sup>2)</sup>	B2	B3	ØB4
LEN0040	203 [7.99]	115 [4.53]	80 [3.15]	158 [6.22]	25 [0.98]	167 [6.57]	20 [0.79]	92 [3.62]	65 [2.56]	-	30 [1.18]
LEN0063	221 [8.70]										
LEN0100	311 [12.24]										
LE0130	328 [12.91]	150 [5.91]	140 [5.51]	273 [10.75]	40 [1.57]	202 [7.95]	15 [0.59]	132 [5.20]	80 [3.15]	-	30 [1.18]
LE0150	324 [12.76]										
LEN0160	262 [10.31]										
LEN0250	412 [16.22]	170 [6.69]	140 [5.51]	352 [13.86]	50 [1.97]	222 [8.74]	10 [0.39]	164 [6.46]	70 [2.76]	-	30 [1.18]
LEN0400	502 [19.76]										
LEN0630	540 [21.26]										
LEN1000	843 [33.19]	210 [8.27]	160 [6.30]	540 [21.26]	60 [2.36]	262 [10.31]	5 [0.20]	204 [8.03]	30 [1.18]	50 [1.97]	40 [1.57]

Type 350...	ØB5	ØB6	ØB7	ØB8	B9	C1 connection				S... (SAE flanges)	C3	C4	SW
						R... (ISO 228)	ØC2	U... (SAE J1926)	ØC2				
LEN0040	64 [2.52]	85 [3.35]	47 [1.85]	32 [1.26]	-	G1/2	28 [1.10]	SAE 10" 7/8-14 UNF-2B	34 [1.34]	-	M6	8 [0.31]	32 [1.26]
LEN0063						G1	41 [1.61]	SAE 12" 1 1/16-12 UN-2B					
LEN0100						G1 1/4	51 [2.01]	SAE 20" 1 5/8-12 UN-2B					
LE0130	92 [3.62]	118 [4.65]				G1 1/2	56 [2.20]	SAE 24" 1 7/8-12 UN-2B	65 [2.56]	SAE 1 1/2" 6,000 psi	M8	12 [0.47]	32 [1.26]
LE0150													
LEN0160	114 [4.49]	140 [5.51]											
LEN0250													
LEN0400													
LEN0630	140 [5.51]	185 [7.28]			10 [0.39]	G2	72 [2.83]	-		SAE 2" 6,000 psi	M12		41 [1.61]
LEN1000	190 [7.48]												

<sup>1)</sup> Servicing height for changing filter element <sup>2)</sup> Dimension B1 is reduced by 4 mm [0.16 in] for SAE flanges

## Maintenance indicator (Dimensions in mm [inch])

Pressure differential indicator with mounted  
M12x1 switching element

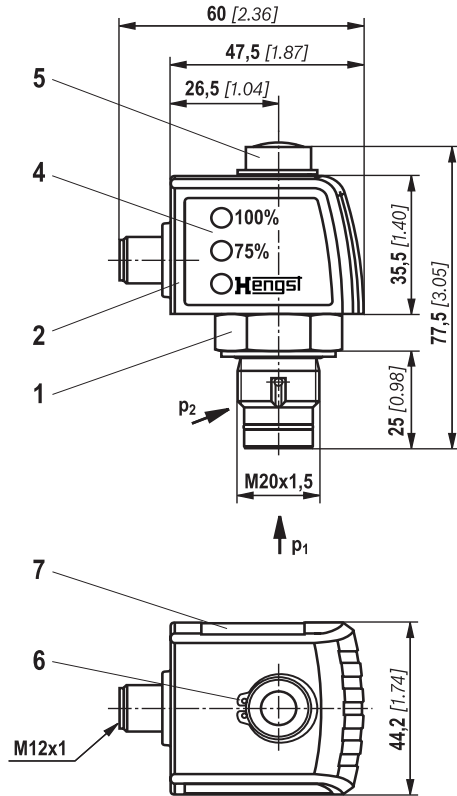

Pressure differential indicator with mounted  
EN 175301-803 switching element

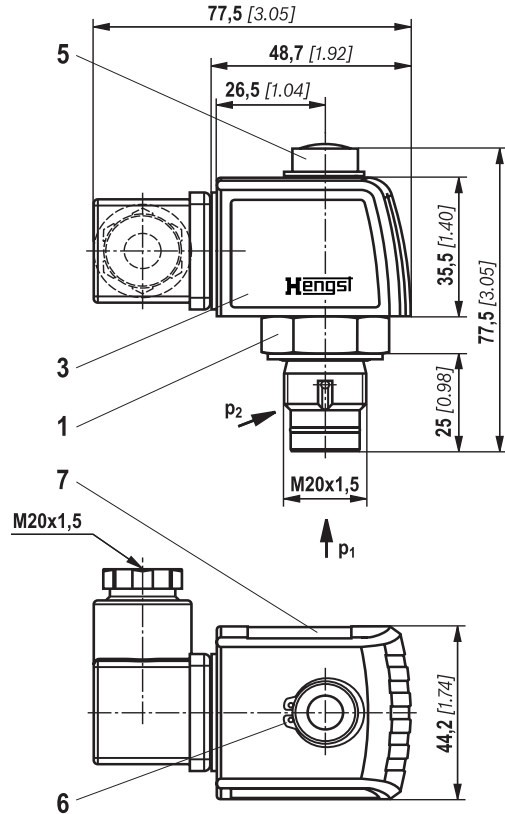

- 1 Mechanical optical maintenance indicator; max. tightening torque  $M_{A \max} = 50 \text{ Nm}$  [36.88 lb-ft]
- 2 Switching element with locking ring for electrical maintenance indicator (rotatable 360°); M12x1, 4-pole round plug-in connection
- 3 Switching element with locking ring for electrical maintenance indicator (rotatable 360°); EN 175301-803 rectangular plug-in connection
- 4 Housing with three LEDs: 24 V =  
green: Stand-by  
yellow: Switching point 75%  
red: Switching point 100%
- 5 Visual indicator with memory function
- 6 16x1 DIN 471 locking ring,  
**Material no. R900003923**
- 7 Name plate

### Important:

Illustration includes a mechanical visual maintenance indicator (1) and electronic switching element (2), (3).

14/20 350LEN0040 to 1000; 350LE0130, 0150 | Inline filter

## Spare parts ordering codes

### Filter element

01	02	03	04	05	06	07
2.			-		-	0

### Filter element

01	Design	2.
----	--------	----

### Size

02	LEN... (Filter element as per <b>DIN 24550</b> )	0040 0063 0100 0160 0250 0400 0630 1000
	LE... (Filter elements as per <b>Hengst standard</b> )	0130 0150

### Filter rating in $\mu\text{m}$

03	<b>Absolute</b> (ISO 16889; $\beta_{x(c)} \geq 200$ )	Glass fiber material, not cleanable	PWR3 PWR6 PWR10 PWR20
	<b>Nominal</b>	Stainless steel wire mesh, cleanable	G10 G25 G40 G60 G100

### Pressure differential

04	Max. admissible filter element pressure differential: 30 bar [435 psi], filter <b>with</b> bypass valve	A
	Max. admissible filter element pressure differential: 330 bar [4,786 psi], filter has <b>no</b> bypass valve	B

### Element design

05	Standard adhesive with galvanized steel	00
	Special adhesive with stainless steel	HV <sup>1)</sup>

### Bypass valve

06	<b>Without</b> bypass valve	0
----	-----------------------------	---

### Seal

07	NBR seal	M
	FKM seal	V
	EPDM seal	E

<sup>1)</sup> Only with FKM or EPDM seal

### Order example:

**2.0100 PWR10-A00-0-M**

**Material no. R928006755**

**For detailed information on Hengst filter elements, see data sheet 51420.**

## Spare parts ordering codes

### Filter element

#### Preferred replacement filter element program

3-micron replacement filter element		6-micron replacement filter element		10-micron replacement filter element	
<b>R928006645</b>	2.0040 PWR3-A00-0-M	<b>R928006646</b>	2.0040 PWR6-A00-0-M	<b>R928006647</b>	2.0040 PWR10-A00-0-M
<b>R928006699</b>	2.0063 PWR3-A00-0-M	<b>R928006700</b>	2.0063 PWR6-A00-0-M	<b>R928006701</b>	2.0063 PWR10-A00-0-M
<b>R928006753</b>	2.0100 PWR3-A00-0-M	<b>R928006754</b>	2.0100 PWR6-A00-0-M	<b>R928006755</b>	2.0100 PWR10-A00-0-M
<b>R928006807</b>	2.0160 PWR3-A00-0-M	<b>R928006808</b>	2.0160 PWR6-A00-0-M	<b>R928006809</b>	2.0160 PWR10-A00-0-M
<b>R928006861</b>	2.0250 PWR3-A00-0-M	<b>R928006862</b>	2.0250 PWR6-A00-0-M	<b>R928006863</b>	2.0250 PWR10-A00-0-M
<b>R928006915</b>	2.0400 PWR3-A00-0-M	<b>R928006916</b>	2.0400 PWR6-A00-0-M	<b>R928006917</b>	2.0400 PWR10-A00-0-M
<b>R928006969</b>	2.0630 PWR3-A00-0-M	<b>R928006970</b>	2.0630 PWR6-A00-0-M	<b>R928006971</b>	2.0630 PWR10-A00-0-M
<b>R928007023</b>	2.1000 PWR3-A00-0-M	<b>R928007024</b>	2.1000 PWR6-A00-0-M	<b>R928007025</b>	2.1000 PWR10-A00-0-M

### Mechanical visual maintenance indicator

01	02	03	04	05	06
<b>W</b>	<b>O</b>	-	<b>D01</b>	-	-

01	Maintenance indicator	<b>W</b>
----	-----------------------	----------

02	Mechanical visual indicator	<b>O</b>
----	-----------------------------	----------

#### Version

03	Pressure differential, modular design	<b>D01</b>
----	---------------------------------------	------------

#### Switching pressure

04	2.2 bar [32 psi]	<b>2.2</b>
	5.0 bar [72.5 psi]	<b>5.0</b>

#### Seal

05	EPDM seal	<b>E</b> <sup>1)</sup>
	NBR seal	<b>M</b>
	FKM seal	<b>V</b>

#### Max. operating pressure

06	Switching pressure of 2.2 bar [31.9 psi]: 160 bar [2,320 psi]	<b>160</b>
	Switching pressure of 5.0 bar [72.5 psi]: 450 bar [6,527 psi]	<b>450</b>
	Switching pressure of 8.0 bar [116 psi]: 450 bar [6,527 psi]	<b>450</b>

<sup>1)</sup> Only with a switching pressure of 5.0 bar

### Mechanical visual maintenance indicator

Material no.	Description
<b>R928038785</b>	WO-D01-8.0-M-450
<b>R901025313</b>	WO-D01-5.0-M-450
<b>R901025312</b>	WO-D01-2.2-M-160
<b>R928038784</b>	WO-D01-8.0-V-450
<b>R901066235</b>	WO-D01-5.0-V-450
<b>R901066233</b>	WO-D01-2.2-V-160
<b>R928054248</b>	WO-D01-5.0-E-450

16/20 350LEN0040 to 1000; 350LE0130, 0150 | Inline filter

## Spare parts ordering codes

### Seal kit

01	02	03	04
D	350/445LE		-

01	Seal kit	D
02	Series	350/445LE

### Size

03	Sizes 0040-0100	N0040-0100
	Sizes 0130-0150	0130-0150
	Sizes 0160-0400	N0160-0400
	Size 0630	N0630
	Size 1000	N1000

### Seal

04	NBR seal	M
	FKM seal	V
	EPDM seal	E

### Seal kit

Material no.	Description
R928028527	D350/445LEN0040-0100-M
R928028530	D350LE0130-0150-M
R928028532	D350/445LEN0160-0400-M
R928028536	D350/445LEN0630-M
R928028537	D350/445LEN1000-M
R928028528	D350/445LEN0040-0100-V
R928028531	D350LE0130-0150-V
R928028533	D350/445LEN0160-0400-V
R928028529	D350/445LEN0630-V
R928028534	D350/445LEN1000-V
R961010717	D350/445LEN0040-0100-E
R961010716	D350LE0130-0150-E
R961010715	D350/445LEN0160-0400-E
R961010714	D350/445LEN0630-E
R961010713	D350/445LEN1000-E

## Assembly, commissioning, maintenance

### Assembly

- ▶ The max. operating pressure of the system cannot exceed the max. admissible operating pressure of the filter (see name plate).
- ▶ When assembling the filter (see also “Tightening torques”), note the flow direction (arrows) and the required servicing height of the filter element (see “Dimensions”).
- ▶ Filter element exchange is made easiest when the filter bowl is oriented downward. Ensure the maintenance indicator is easily visible.
- ▶ Remove the plastic plugs in the filter inlet and outlet.
- ▶ Make sure power is disconnected during assembly.
- ▶ The optional electrical maintenance indicator is connected using the electronic switching element with 1 or 2 switching points, which is placed on the mechanical visual maintenance indicator and held in place by a locking ring.

### Commissioning

- ▶ Commission the system.

 **Important:**

The filter has no bleeding mechanism.

### Maintenance

- ▶ If the red indicator pin rises out of the mechanical visual maintenance indicator and/or the electronic switching element switches at operating temperature,

the filter element is dirty and has to be replaced/ cleaned. For more details, see data sheet 51420.

- ▶ The material number of the correct replacement filter element is on the name plate of the complete filter. Verify that it matches the material number on the filter element.
- ▶ Decommission the system.
- ▶ Release operating pressure on the system side.

 **Important:**

The filter has no bleeding mechanism.

- ▶ Drain the oil on the dirt side using the drain screw (size 0160 and larger).
- ▶ Unscrew the filter bowl (or base if size 1000).
- ▶ Slightly turn the filter element to remove it from the spigot.
- ▶ Clean the filter components as needed.
- ▶ Check the seals on the filter bowl for damage and replace them as needed.  
For compatible seal kits, see “Spare parts”.
- ▶ Wire mesh filter elements can be cleaned. For detailed cleaning instructions, see data sheet 51420.
- ▶ Slightly turn the new or cleaned filter element to install it on the spigot.
- ▶ Assembly is reverse of removal.
- ▶ Note the torque specifications (“Tightening torques”).
- ▶ Commission the system.

 **WARNING**

- |   |   |
|---|---|
| <ul style="list-style-type: none"> <li>▶ Only install or remove when system is not pressurized.</li> <li>▶ Filter is pressurized.</li> <li>▶ Only remove filter bowl when it is not pressurized.</li> <li>▶ Do not replace maintenance indicator when filter is pressurized.</li> </ul> | <ul style="list-style-type: none"> <li>▶ Failure to observe flow of direction during assembly will cause filter element to be damaged beyond repair. Particles will enter the system and damage downstream components.</li> </ul> |
|---|---|

 **Important:**

- ▶ Only trained specialists may work on the filter.
- ▶ The safety and functionality of the filter are only guaranteed with original Hengst spare parts.
- ▶ The warranty will be void if the delivery item is

modified or improperly mounted, installed, maintained, repaired or used by the ordering party or a third party, or exposed to environmental conditions exceeding our installation conditions.

18/20 **350LEN0040 to 1000; 350LE0130, 0150** | Inline filter

## Tightening torques

### Mounting

Series 350...	LEN0040	LEN0063	LEN0100	LE0130	LE0150	LEN0160	LEN0250	LEN0400	LEN0630	LEN1000
Screw/tightening torque when $\mu_{total} = 0.14$	Nm [lb-ft]		M6/4.5 [3.3] ± 10%			M8/10.5 [7.7] ± 10%		M12/37 [27.3] ± 10%		
Quantity	4									
Recommended screw property class	8.8									
Min. screw-in depth	mm [inch]		6 [0.24] + 1 [0.04]			10 [0.4] + 2 [0.08]				

### Filter bowl and maintenance indicator

Series 350...	LEN0040	LEN0063	LEN0100	LE0130	LE0150	LEN0160	LEN0250	LEN0400	LEN0630	LEN1000
Filter bowl	Screw in filter bowl as far as it will go, then unscrew 1/8 to 1/2 turn									
Maintenance indicator	Nm [lb-ft]		Max. 50 [36.9]							
EN 175301-803 switching element cubic connector screw	Nm [lb-ft]		M3/0.5 [3.7]							

## Directives and standardization

### Product validation

Hengst filters, the filter elements built into them and filter accessories are tested and quality-monitored according to different ISO test standards:

Pressure pulse test	ISO 10771:2015-08
Filtration performance test (multipass test)	ISO 16889:2008-06
$\Delta p$ (pressure loss) characteristic curves	ISO 3968:2001-12
Compatibility with hydraulic fluid	ISO 2943:1998-11
Collapse pressure test	ISO 2941:2009-04

The development, manufacture and assembly of Hengst industrial filters and Hengst filter elements is carried out within the framework of a certified quality management system in accordance with ISO 9001:2015.

### Classification according to the Pressure Equipment Directive

Inline filters for hydraulic applications as per 51422 are considered pressure holding equipment under Article 1 Section 2.1.4 Pressure Equipment Directive 97/23/EC (PED). However, under Article 1 Section 3.6 PED, hydraulic filters are exempt from the PED if they are not classified

higher than Category I (Guideline 1/19).

The fluids from "Compatibility with permitted hydraulic fluids" were considered for the classification.

They do not receive a CE mark.

### Use in explosive areas as per Directive 94/9/EC (ATEX)

Inline filters as per 51422 are not equipment or components in terms of Directive 94/9/EC and do not receive a CE mark. The ignition risk analysis showed that these inline filters do not have their own ignition sources as per DIN EN 13463-1:2009.

DIN EN 60079-14:2012 – be used in intrinsically safe electric circuits (Ex ib) in systems without requiring marking and certification.

Inline filters and the electronic maintenance indicators described here can be used in the following explosive areas:

According to DIN EN 60079-11:2012, electronic maintenance indicators with a switching point:

WE-1SP-M12x1 **R928028409**

WE-1SP-EN175301-803 **R928036318**

are considered simple electronic operating equipment that does not have its own voltage source. This simple electronic operating equipment may – according to

	Zone suitability	
Gas	1	2
Dust	21	22

Hengst Filtration GmbH, RE 51422, edition: 2021-04

Knowledge is POWER – Motion Force Control is our Business

HYQUIP Limited New Brunswick Street Horwich Bolton Lancashire BL6 7JB UK

## Directives and standardization

Complete filter with mech. visual maintenance indicator			
Use/classification		Gas 2G	Dust 2D
Classification		Ex II 2G c IIC TX	Ex II 2D c IIC TX
Medium conductivity	pS/m	min.	300
Dust accumulation		max.	–
			0.5 mm

Electronic switching element in intrinsically safe electric circuit			
Use/classification		Gas 2G	Dust 2D
Classification		Ex II 2G Ex ib IIB T4 Gb	Ex II 2D Ex ib IIIC T100 °C Db
Admissible intrinsically safe electric circuits		Ex ib IIC, Ex ic IIC	Ex ib IIIC
Technical data		Values only for intrinsically safe electric circuit	
Switching voltage	Vi	max.	150 V AC/DC
Switching current	Ii	max.	1.0 A
Switching power	Pi	max.	1.3 W T4 T <sub>max</sub> 40 °C
		max.	1.0 W T4 T <sub>max</sub> 80 °C
Surface temperature <sup>1)</sup>		max.	–
Inner capacitance	Ci		100 °C
Inner inductance	Li		Negligible
Dust accumulation		max.	–
			0.5 mm

<sup>1)</sup> Temperature is based on the temperature of the medium in the filter and cannot exceed this value.

Possible circuit as per DIN EN 60079-14

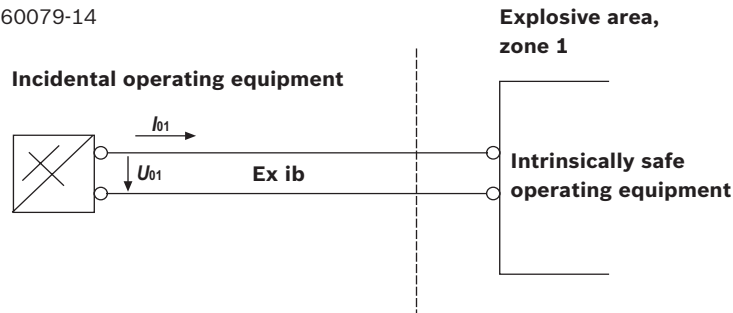

### ⚠ WARNING

- ▶ Explosion hazard due to high temperature. Temperature is based on temperature of medium in hydraulic circuit and cannot exceed this value. Take steps to make sure max. admissible ignition temperature is not exceeded in explosive area.
- ▶ Make sure potential equalization is sufficient when using 51422 inline filters in explosive areas. Ground-

ing the filter with mounting screws is recommended. Note that paint and oxide protective coating are not electrically conductive.

- ▶ When replacing filter element, remove packaging material from explosive area around replacement element.

### 👉 Important:

- ▶ Safety and functionality of the filter are only guaranteed with original Hengst spare parts.

- ▶ Maintenance may only be performed by specialists on instruction of the owner in accordance with Directive 1999/92/EC Annex II Section 1.1.